

Solar inverter automatic dispatching system

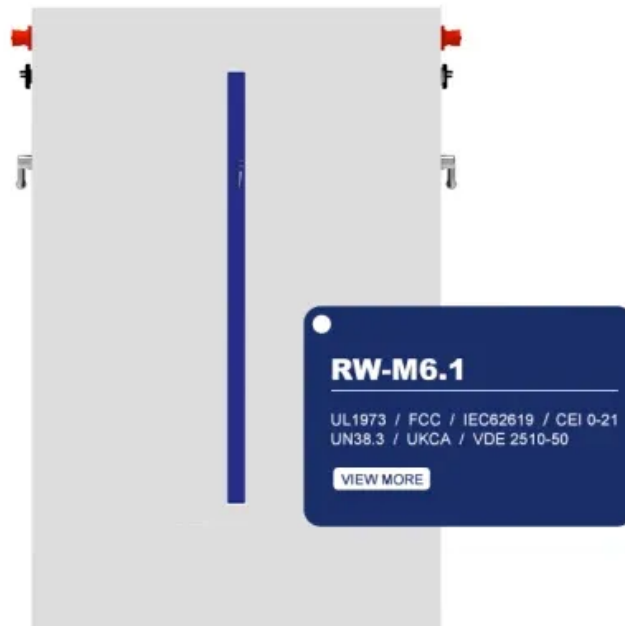

Overview

Automatically detect inverter failures, notify technicians, and dispatch emergency service crews within minutes—minimizing downtime and protecting energy production revenue. gov Available for sale to the public, in paper, from: U. Department of Commerce National Technical Information Service 5301 Shawnee Road Alexandria, VA 22312 NTIS 6847 or. Are you looking for reliable dispatching control for photovoltaic power plants over 100 kWp?

Benefit from a complete certified turnkey solution with the Patron control unit (RTU)., in the. Distributed photo-voltaic (DPV) systems with smart inverters can be controlled to adjust active power and reactive power outputs, and they are envisioned to become a part of (centrally or distributed) controllable assets managed by the ADMS for optimizing grid operations., can solve the problem of thermal power increasing the difficulty of power system balance, and achieve the effect of improving transmission quality and. In this paper, we propose an active-reactive coordinated control strategy called AGVC that considers the dependability of inverter components to simultaneously enhance the response of AGC and AVC. Firstly, we introduce a data-driven method for assessing component dependability which employs a.

Solar inverter automatic dispatching system



Automatic dispatching system based on solar power generation

The invention provides an automatic dispatching system based on solar power generation. The automatic dispatching system comprises a foundation platform, a monitoring ...

Automated Solar Inverter Failure Dispatch , Emergency Response ...

This automated emergency dispatch system monitors inverter performance in real-time, instantly detects failures or critical errors, and automatically dispatches qualified technicians to affected sites.

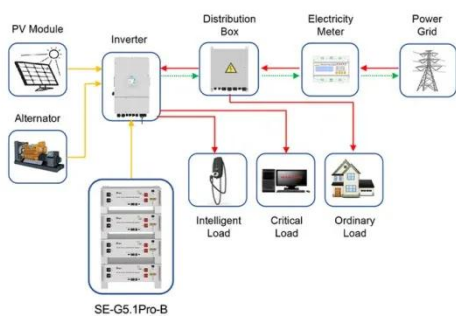

Application scenarios of energy storage battery products

Dispatching control of PV plants , Unipi

Are you looking for reliable dispatching control for photovoltaic power plants over 100 kWp? Benefit from a complete certified turnkey solution with the Patron control unit (RTU).

An Overview of the Automated Dispatch Controller Algorithms in ...

Three automatic dispatch modes have been added to the battery model within the System Advisor Model (SAM). The modes provide users the option to evaluate different strategies for peak-shaving ...



Optimal dispatch of PV inverters in unbalanced distribution systems

In this paper, a Reinforcement Learning (RL)-based approach to optimally dispatch PV inverters in unbalanced distribution systems is presented.

A Data-Driven Coordinated Active and Reactive Dispatching

We propose a novel AGC and AVC joint dispatching system that enables adaptive active and reactive power dispatching for photovoltaic arrays. This system aims to meet the frequency and ...



Optimal Energy Dispatch of

Distributed PVs for the Next ...

The pro-posed optimal energy dispatch is implemented using an open-source ADMS platform, and simulation results have demonstrated the effectiveness of the proposed approach on improving ...



Extended Sensitivity-Aware Reactive Power Dispatch Algorithm ...

This paper extends a sensitivity-aware reactive power dispatch algorithm tailored to manage smart inverters operating under different control modes, including PQ, PV, and Volt-Var (VV).



(PDF) Design and Implementation of a Power Dispatch Controller for

Manual changeovers often result in power mismatch and energy inefficiencies, resulting in the need for an automated power dispatch control system. This study explores the use of an Arduino



Solar Dispatcher

Photovoltaic, monitoring, dispatching,
data logger, pv system tracking, system
fault detection



Contact Us

For catalog requests, pricing, or partnerships, please visit:
<https://www.59empagm.pl>

